

ASD-CERT

QUALITY MANUAL

ASD-CERT

QUALITY MANUAL

This Quality Manual, issue 008, has been approved by:

.....Eric Herbay, Quality Manager

and has been authorized and released on 29th January, 2008 by:

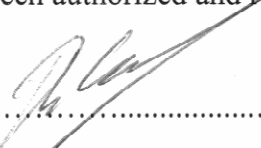
....., Philippe Canteau, Chairman

PREFACE

This document is the Quality Manual of ASD-CERT, a certification body established by the members of ASD, the AeroSpace and Defence Industries Association of Europe.

Its purpose is to certificate standard aerospace products, particularly those defined by EN Standards, to support the European Aerospace Industries. The standards used are prepared and maintained by standardization organizations. They specify products to be used by the aerospace industries.

It is ASD-CERT's objective to support the aerospace industry as a means to comply with the process of satisfying the requirements of suppliers control e.g. airworthiness authorities, quality standards and, as appropriate, other agencies, e.g. military and space.

ASD-CERT is a 2nd party certification scheme.

This Quality Manual consists of two parts:

Part 1: Exposition

This part addresses the requirements of EN45011, "General Criteria for Certification Bodies operating Product Certification", and of EN45012, "General Criteria for Certification Bodies operating Quality System Certification".

Part 2: ASD-CERT Procedures

These procedures were first published in 1991, and are subject to regular reviews. Any comments thereto shall be directed to:

ASD-CERT
Secretary General
Avenue de Tervuren, 270
1150 Brussels
Belgium

CONTENTS

	Page
Preface	i
Contents	ii
Quality Manual Control	ii

Part 1 Exposition**Part 2 ASD-CERT Procedures****QUALITY MANUAL CONTROL**

This Quality Manual is controlled by means of the issue as given on top of each page. The Manual is released after approval by the Quality Manager and after authorization by the Chairman and supersedes all previous similar documents.

ISSUE	ISSUE DATE	RATIONAL
001	1991	
002	1995	
003	28 Jan. 1997	
004	30 April 1998	
005	31 March 1999	
006	31 Aug. 2001	
007	31 Jan. 2004	
008		

PART 1

EXPOSITION

CONTENTS

CHAPTER	TITLE	EN 45011/45012 CLAUSES	PAGE
1.1	Quality Policy Statement	12 a)	3/8
1.2	Administrative Structure	4; 12 b)	3&4/8
1.3	Terms of Reference of the Governing Board	5; 12 c)	4/8
1.4	Organizational Structure	6; 12 c), f)	5/8
1.5	Certification Personnel	7; 12 d), e)	5/8
1.6	Documentation and Change Control	8	5/8
1.7	Records	9	5/8
1.8	Certification procedures	10; 12 g), i), j)	6/8
1.9	Facilities Required	11; 12 h)	6/8
1.10	Quality Manual	12	6/8
1.11	Confidentiality	13	6/8
1.12	Publications	14	6/8
1.13	Appeals	15; 12 k)	7/8
1.14	Internal Audit and Periodic Review	16	7/8
1.15	Complaints	17	7/8
1.16	Withdrawal and Cancellation of Certificates	18	7&8/8
1.17	Liability	19	8/8

1.1 QUALITY POLICY STATEMENT

ASD-CERT certifies standard aerospace products and approves the quality system of their manufacturers in accordance with the requirements of EN9133, “Qualification procedure”, and EN9100, “Approval of the quality system of manufacturers”. Certification is directed particularly to EN aerospace products, but under controlled conditions products may be certificated conforming with standards prepared and maintained by other standardization organizations.

Certification is performed for the benefit of the aerospace industries of Europe, as associated in ASD. ASD-CERT, a 2nd party scheme, will meet the requirements of EN45011 and 45012, covering certification bodies that certificate products and approve quality systems, except the requirements regarding impartiality.

A Quality Manager is appointed with responsibility for quality assurance of the operations of ASD-CERT.

Operations are performed by Mandated Bodies, which are designated by the Executive Board of ASD-CERT in accordance with the relevant procedures. Basic requirements for organizations to obtain a mandate comprise their approval from an airworthiness authority, or equivalent, to produce aerospace materiel, their compliance with EN9100 and, for laboratories, their certification by an appropriate certification organization.

A close working relationship is established with ASD-EASE, European Aerospace Supplier Evaluation, a 2nd party scheme to assess quality systems of suppliers to the aerospace industry.

ASD-CERT takes account of and applies within its procedures the documents EN9100, EN9104, EN9104-2 and EN9104-3.

1.2 ADMINISTRATIVE STRUCTURE

ASD-CERT is a certification body for the European Aerospace Industries, set up by ASD, the AeroSpace and Defence Industries Association of Europe. It is an Association according to Belgian law, located in Brussels and operating from the ASD office in Brussels.

ASD-CERT is governed by Statutes as expanded in this Exposition.

The operations are performed according to the procedures as presented in Part 2 of this Manual.

ASD-CERT Governing Board consists of

- representatives of all members either nominated by the ASD members or nominated by companies being direct members, (one representative per National Trade Association/company),
- representatives of the Airworthiness and Quality Committees of ASD,
- representatives of ASD-STAN, and ASD-EASE. Furthermore an observer from CEN/CENELEC attends the Board meetings, because ASD-STAN is an associated standardization body of CEN/CENELEC.

The Chairman of the Governing Board is the “Senior Executive”.

As agreed between ASD and ASD-CERT the function of the Secretary General will be assigned to a person from ASD staff.

An Executive Board directs the general administration of ASD-CERT.

1.3 TERMS OF REFERENCE OF THE GOVERNING BOARD

The Governing Board is responsible for:

- * statutes and procedures;
- * composition of ASD-CERT Board;
- * policy matters concerning the operations of ASD-CERT;
- * finances;
- * delegation of executive activities.

The Governing Board designates from its members:

- * the Chairman;
- * two Vice Chairmen;
- * the Treasurer;
- * the Quality Manager.

These officers and the Secretary General form the Executive Board.

The Executive Board is delegated by the ASD-CERT Governing Board to perform executive activities and is responsible for:

- * implementation of policies;
- * designation of “Mandated Bodies”;
- * examining reports from Mandated Bodies;
- * granting certificates;
- * finances;
- * reporting to ASD-CERT Governing Board.

The responsibilities of the officers are mentioned below.

The Chairman acts on behalf of the Governing Board and is responsible for ensuring that decisions of the Board are properly carried out.

Each Vice-Chairman may act as Chairman when the latter is absent. The Treasurer prepares the annual budget and monitors the finances.

The Quality Manager establishes objective evidence that ASD-CERT complies with this Quality Manual and has the authority to request corrective actions. He approves this Manual.

The Secretary General performs all administrative and treasury tasks. Furthermore, he carries out the activities delegated to him by the Executive Board. He publishes the list of certificated aerospace products and their manufacturers.

1.4 ORGANIZATIONAL STRUCTURE

An Organizational Chart is presented in figure 1.

Finances needed to operate ASD-CERT are recovered from the manufacturers of aerospace products certificated by ASD-CERT. Prices are available on the A Cert web site, or by application to the Secretary general.

The certification system of ASD-CERT consists of assessments, qualification testing and inspections carried out by Mandated Bodies, followed by certification of the aerospace products and approval of the quality system of their manufacturers by the ASD-CERT Executive Board. This is elaborated in the procedures of Part 2 of this Manual.

ASD-CERT is an Association according to Belgian law of 1901 and located in 1150 Brussels, Avenue de Tervuren, 270.

1.5 CERTIFICATION PERSONNEL

Within the aerospace industry it is long standing practice that all personnel shall be competent, trained and qualified for their tasks. This applies to Mandated Bodies as well. Their capabilities in this respect are assessed as to obtain an approval from an authority or a certificate from a certification body. This also holds for the members of the ASD-EASE organization who may act as Mandated Bodies. In the ASD-EASE Quality Manual the relevant requirements are incorporated.

1.6 DOCUMENTATION AND CHANGE CONTROL

Documentation used by ASD-CERT comprises this Quality Manual, the standards which define the aerospace products to be certificated and the EN standards 2000, 9100, 9133, 45001, 45002, 45011 and 45012.

Control of this Quality Manual is as specified on page ii; the standards are controlled by CEN.

The lists of certificated aerospace products and their manufacturers are published and updated periodically by ASD-CERT Secretary General.

1.7 RECORDS

For each certification a file will be established containing the relevant documents, particularly the reports from the Mandated Bodies and the certification procedure. Furthermore the data regarding mandating of these bodies shall be recorded.

The above files will be retained for 5 years after the product certificate is withdrawn and/or cancelled.

Minutes of meetings of ASD-CERT Board are retained for 9 years. Audit reports from the

Quality Manager are retained for five years.

1.8 CERTIFICATION PROCEDURES

Assessments, qualification testing and inspections will be carried out or monitored by Mandated Bodies. Mandating is a task of the ASD-CERT Executive Board according to the relative procedure in Part 2 of this Manual.

The reports of the Mandated Bodies are judged and acknowledged by the Executive Board after which it certifies the standard aerospace products concerned. Furthermore the quality systems of the manufacturers which produce these standard aerospace products will be approved. This approval is either based upon the registration in IAQG OASIS system or the an appropriate audit performed by ASD-EASE. These judgments are made against the criteria of the relevant standards.

The certificates issued to the manufacturers of standard aerospace products remain the property of ASD-CERT.

1.9 FACILITIES REQUIRED

The facilities required comprise competent, qualified and experienced personnel and adequate accommodation and equipment for testing and inspection. This applies particularly to the Mandated Bodies who will be assessed for the proper availability of these facilities as part of their approval by an authority or a certification body.

1.10 QUALITY MANUAL

The requirements of Clause 12 of EN45011 and EN45012 are reflected in this Quality Manual by which compliance with the two EN standards is demonstrated.

1.11 CONFIDENTIALITY

All data regarding certification of aerospace products is confidential between ASD-CERT Executive Board, Mandated Bodies and each manufacturer. Upon request certification information may be obtained through ASD-CERT. The only public information is published in the list of certificated aerospace products and their manufacturers.

Also the data regarding mandating of Mandated Bodies is confidential.

1.12 PUBLICATIONS

ASD-CERT publishes the results of its certification activities in a list of certificated aerospace products and their manufacturers. This list is periodically updated, is given the format of an ASD Technical Report, TR 3040, and can be found on ASD-CERT website

www.asd-cert.org

1.13 APPEALS

ASD-CERT Board has instituted an Appeal Panel which has the authority to decide on appeals from manufacturers or Mandated Bodies against decisions of the Executive Board which have an impact upon them.

The Panel consists of the Chairmen of ASD 's Quality Committee and ASD-STAN, and a third member appointed by them.

1.14 INTERNAL AUDIT AND PERIODIC REVIEW

The Quality Manager is responsible for auditing and reviewing the operations of ASD-CERT. These audits and reviews will be conducted at least once a year and further as deemed necessary by him. Corrective actions will be established and be implemented.

The Quality Manager will report the results of his audits and reviews to the Board.

1.15 COMPLAINTS

In the certification agreements between ASD-CERT and manufacturers of certificated aerospace products it is a requirement that complaints received by such manufacturers shall be recorded by them and proper corrective and preventive actions shall be taken and be recorded. Such records shall be made available to ASD-CERT during surveillance activities.

1.16 WITHDRAWAL AND CANCELLATION OF CERTIFICATES

There are circumstances when it is necessary to withdraw and cancel certificates; as follows:-

- a standard is cancelled
- a manufacture ceases production of a certificated product
- a manufacturer loses its Quality Management System approval
- a manufacturer misuses a certificate, e.g. publishes misleading articles or publications
- a manufacturer ceases trading
- a manufacturer changes its name and/or address

The decision to withdraw and cancel a certificate shall be taken at the at the first available opportunity by the Executive Board. Upon confirmation of the decision to 'withdraw and cancel' ASD-CERT shall:-

- write to the manufacturer concerned confirming the decision and requesting immediate return of the subject certificate(s)
- update the TR3040-1 and TR3040-2 reports
- advise ASD-STAN

1.17 LIABILITY

- ASD-CERT cannot and will not replace any Aerospace Type Certification activities. It determines that a product meets, at a given time, those requirements laid down in a respective (inter-) national standard.
- The Association, its servants or representatives accept no responsibility for the continued quality of products produced against relevant specifications, this responsibility remaining with the purchaser.
- The report TR3040-2 brings together information showing those manufacturers who have successfully completed qualification testing as required by the appropriate technical specification, for the manufacture of standard products.
- Users of the report are reminded that qualification testing is designed only to determine that the manufacturer has the capability to produce a particular item by a declared manufacturing process. The acceptance of production batches is a matter for agreement between the manufacturer and the purchaser.
- It is required that at the time of qualification the mandated body ensures that the company being approved operates a quality system in accordance with the EN9100 standard. It is however, the responsibility of the purchaser carrying out a design activity and selecting a part from the TR3040-2 report, to ensure that the company they have selected to supply the qualified product operates a manufacturing quality system that is acceptable to them and maintained to their satisfaction.
- The standard part manufacturer remains 100% responsible for the quality of parts he manufactures regardless of any qualification certificate he may obtain from a mandated Body.

ASD-CERT Organization Chart

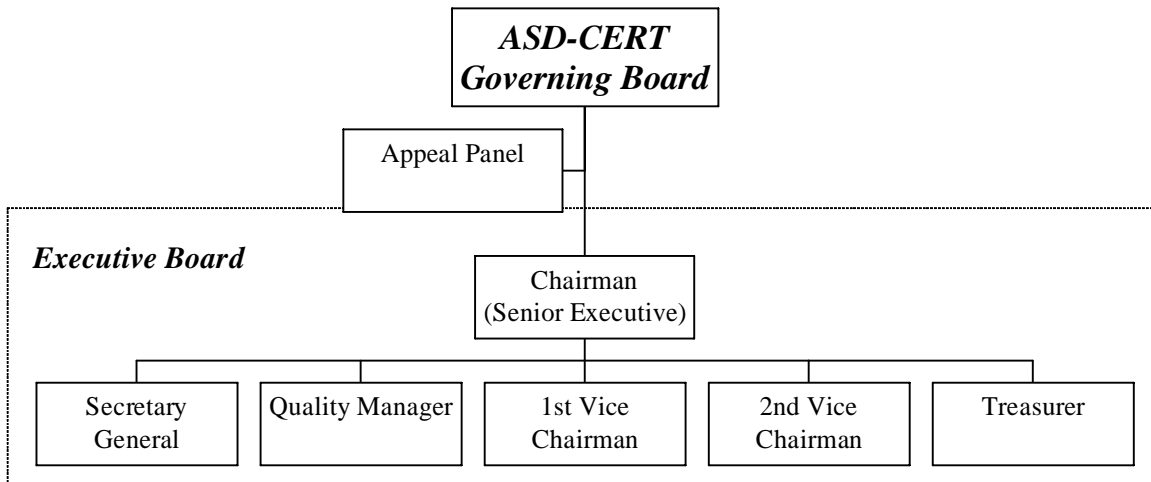

PART 2

ASD-CERT PROCEDURES
(ACP's)

CONTENTS

NUMBER	TITLE	Issue
ACP001	ASD-CERT Certification Procedure for Standard Aerospace Products	008
ACP002	Mandated Bodies	008
ACP003	Application for Product Certification	008
ACP004	Quality System Assessment - Procedure	008
ACP005	Product Certification - Procedure	008
ACP006	Manufacturing Records	008
ACP007	Control of Stamps	002
ACP008	Procedure for Manufacturing Change Request (MCR)	008
ACP009	Problems with Standard Aerospace Products - Reports by Users	008
ACP010	Appeal Procedure	008
ACP014	ASD-CERT Secretary General Office	008
ACP016	Abbreviations	008

FORMS TO ACP's

ACP003 - FORM01	Application for Product Certification
ACP004 - FORM01	Quality System Audit - Summary and Recommendations
ACP005 - FORM01	Product Qualification Testing - Summary and Recommendation
ACP008 - FORM01	Manufacturing Change Request (MCR)

Note: ACP000, 011, 012, 013 and 015 have been cancelled.

AECMA-CERT CERTIFICATION PROCEDURE FOR STANDARD AEROSPACE PRODUCTSPurpose

To describe the process by which it is demonstrated that standard aerospace products conform with the requirements of the technical standards referring to these parts and for a manufacturer of such parts to operate a quality system at least equivalent to EN9100; see diagrams on page 5

Definitions:

- Mandated Body: Organisation or person tasked by ASD-CERT with assessing whether the manufacturer's products comply with the relevant standards and whether the manufacturer's quality system complies with EN9100. For complex products or process EN9103 could be used if so decided by the mandated body. In this case, the key characteristics are identified in the Technical Specification for the parts to be qualified.
- Product means: Part, process, material.
- Product Qualification Certificate: A serialised document that certifies that a product has been qualified according to the relevant standards, established by an appropriate organisation.
- User: An organisation purchasing specific aerospace qualified products.
- Manufacturer: Company or organisation manufacturing the products to be qualified and meeting the requirements of EN9100. A manufacturer is assumed to be located in the place where the product is made.

Application Process

Manufacturers seeking to have a product qualified shall apply to ASD-CERT specifying:

- the description of the product to be certified, identifying the applicable specifications and the relevant qualification standard to be used;
- an overview of the company (organisation, products manufactured, manpower, facilities, etc.);
- a list of approvals and/or qualifications already granted and, if any, information on results of evaluations already performed.

This shall be accompanied by a certificate showing compliance to EN9100 carried out by a

body acceptable to ASD-CERT plus any other required certifications/accreditations from relevant organisations.

After examining the information above ASD-CERT shall forward it to the Mandated Body.

Qualification Procedure

The Mandated Body shall:

- ❖ request the manufacturer to implement a qualification test programme and to specify the place and facilities proposed to achieve this programme
- ❖ evaluate the Qualification Test Programme (QTP) including test procedures
- ❖ define time scales for completion of the QTP
- ❖ ensure that the QTP is correctly achieved
- ❖ ensure that a Qualification test Report (QTR) documenting the result of the QTP is prepared
- ❖ Ensure that the QTR prepared by the manufacturer contains the following :
 - A list of all the tests carried out in accordance with the QTP, including issue date of all relevant standards and documents
 - A full list of quantitative test results and a summary sheet giving the results of tests not as pass/fail, but with values
 - Reference number of the agreed and frozen manufacturing and inspection file (issue, date, index)
- ❖ have access during all stages of the manufacturing and test programme and to manufacturing and inspection data for the product
- ❖ ensure all tools and test equipment used in the qualification are in calibration and being used correctly
- ❖ ensure the product to be evaluated has been manufactured and inspected as applicable to production parts
- ❖ reserve the right to proceed to verification test and have counter test performed when it is deemed necessary

- ❖ ensure that the significant manufacturing operations and parameters are identified, that these operations and parameters are recorded, design and manufacturing drawings are recorded and all signed by representatives of both the Mandated Body and the manufacturer (signed and sealed) The manufacturer shall undertake not to change anything without the express written approval of ASD-CERT.

After examination of the test results the Mandated Body shall write a Product Qualification test report (PQTR) and forward a copy to ASD-CERT and the manufacturer.

This report shall contain at least the following:

- a recommendation of the acceptance or otherwise of the qualification
- any required corrective action and its compliance

Note:

Mandated Body reports may be submitted in English (preferred), French or German. A summary report shall be prepared in English

Certification Procedure

After consideration of the test report, ASD-CERT shall decide (after taking into account the recommendations from the Mandated Body) whether or not to grant the manufacturer a product qualification certificate for the product concerned. See ACP 005.

The certificate shall contain the following minimum information:

- name of the manufacturer of the product
- where the product was manufactured
- the product designation based on the product standard, part number of the product qualified and reference number of technical specification the part was qualified to
- the Qualification Test Report number
- a serial number, issue and granting date of the certificate
- a validity period of 3 years
- reference to the approved quality system.

Maintenance

Three months before the end of the validity period ASD-CERT shall have a Mandated Body perform an audit on the manufacturer to verify that the manufacturing process is still valid and then make a recommendation to ASD-CERT whether or not the qualification can be continued. This process of qualification renewal is dependant upon the intention of the manufacturer to continue the production of the standard.

A user may conduct or have conducted on his behalf, complimentary evaluations which he judges are necessary.

In case of dispute, appeal can be made to ASD-CERT appeal committee.

The manufacturer shall inform ASD-CERT when

- any change in his quality system might affect the granted approval
- any evolutions occur in the company situation (merger, take-over, winding up, change of name, change of premises, etc.)
- any proposed modification in manufacturing or inspection (significant operations and/or parameters, process change, place change of manufacture, change of sub suppliers, etc.).
- restart of production is planned after a break of more than 18 months

ASD-CERT will examine each case and give a considered verdict.

This may include a request to the mandated body for additional assessment.

Any information given to ASD-CERT shall be treated with its confidentiality requirements, but any other applicant has the right to examine the QTP and QTR.

Users of ASD-CERT qualified aerospace products shall report to ASD-CERT any failure or problems relative to the qualified aerospace products.

In the case of complaint from the users to ASD-CERT on the performance of a qualified aerospace product provided with a qualification certificate, and after due consideration by the Executive Board, ASD-CERT may request a Mandated Body to perform an investigation and/or audit at the place of manufacture and reports its findings. After consideration of the investigation and audit reports by the Executive Board, particularly the need for partial or full requalification of the product, or removal of qualification certification, the SG shall formally notify the manufacturer of the decision taken.

The SG shall maintain records of complaints, investigation and audit reports, meeting decisions and relevant correspondence.

Product Qualification Process

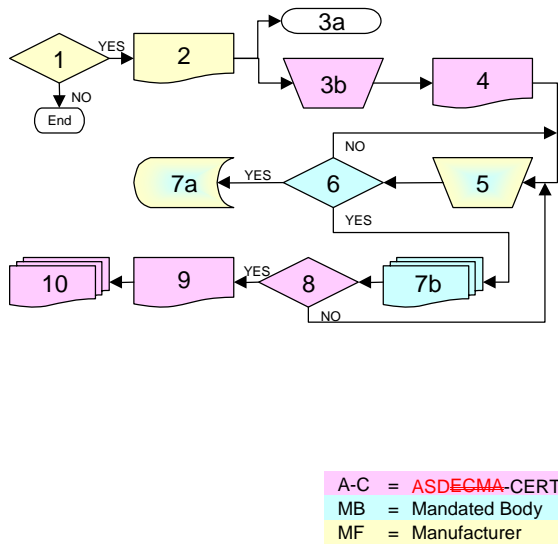

Ref.	Description	Actionee
1	Product standard requires EN2000 assessment and EN 9133 qualification	MF
2	Sent application form to A-C for quality system assessment and product qualification (ACP003 Form1)	MF
3a	for system assessment see next page	
3b	Selection of the MB for product qualification	A-C
4	Information for MF and nominated MB to start qualification process	A-C
5	Product qualification process	MF, MB
6	MB satisfied with the qualification results	MB
7a	Frozen manufacturing route	MF, MB
7b	Provide written recommendation for qualification to A-C (ACP005 Form1) and qualification report	MB
8	Acceptance of the Executive Board	A-C
9	Issue a Product Qualification Certificate	A-C
10	Amend TR 3040-2. List of qualified products	A-C

Quality System Approval Process*

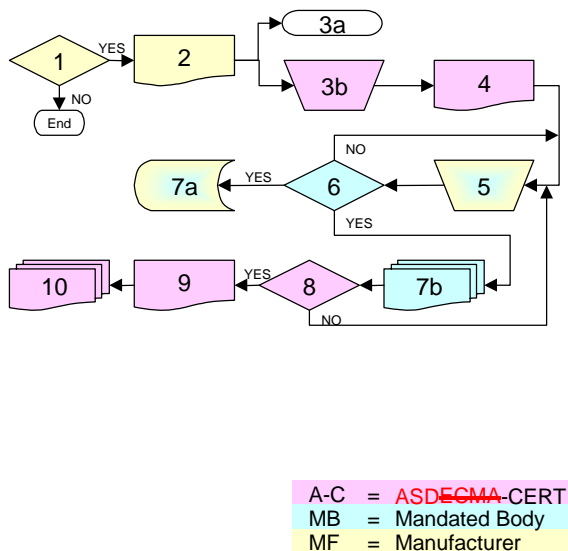

Ref.	Description	Actionee
1	Product standard requires EN2000 assessment and EN 9133 qualification	MF
2	Sent application form to A-C for quality system assessment and product qualification (ACP003 Form1)	MF
3a	for product qualification see previous page	
3b	Selection of the MB for quality system assessment	A-C
4	Information for MF and nominated MB to start qualification process	A-C
5	Quality system assessment process	MF, MB
6	MB satisfied with the assessment results	MB
7a	Agreed quality manual	MF, MB
7b	Provide written recommendation for system approval to A-C (ACP004 Form1) and assessment report	MB
8	Acceptance of recommendation by the Executive Board	A-C
9	Issue a Quality System Approval Letter	A-C
10	Amend TR 3040-1. List of approved manufacturers	A-C

*Note: The process for Quality System approval by ASD-CERT applies to exceptional cases only. ASD-CERT usually accepts proof of EN 9100 QMS conformity based upon IAQG OASIS or ASD-EASE EASIS data.

MANDATED BODIES**Purpose**

To define criteria for Mandated Bodies which may perform assessment or qualification tasks and to provide the procedure for their designation.

Criteria for Mandated Bodies

Organizations may become Mandated Bodies when they meet the following criteria:

- 1 they have an approval from an aviation authority or equivalent agency to design and produce aircraft, engines, space products or equipment;
- 2 they comply with EN 9100 requirements;
- 3 if, as a member of ASD-EASE, they are prepared to comply with that Association's requirements when they assess quality systems, particularly the use of questionnaires and availability of qualified auditors.

Procedure for designation

- 1 Any organization meeting the above criteria may be designated as Mandated Body for particular assessment or qualification tasks.
- 2 The Secretary General shall keep file of each designation and shall maintain a register of Mandated Bodies.

Notes

Mandated Bodies will:

- receive a copy of the ASD -CERT Quality Manual.
- settle the costs involved in their activities directly with the manufacturer concerned.
- advise the SG of the names of staff authorised to sign ACP004 and/or ACP005 forms, and the holder of the ASD-CERT stamp
- will advise the SG of changes to authorised staff
- will advise the SG of points of contact for Quality System Approval and Product Certification
- work in close collaboration with the SG managing the qualification process
- receive a copy of the ASD-CERT product qualification certificate from the SG

APPLICATION FOR PRODUCT CERTIFICATION

Purpose

To provide the procedure to be followed by a manufacturer applying for product certification.

Procedure

Upon applying for certification the Secretary General, SG, will send the manufacturer ACP003 - FORM01 and the ASD-CERT Quality Manual.

1. The manufacturer shall return the form together with the requested information.
2. The SG will select the Mandated Body to perform the tasks required for certification.

The criteria for selection of a Mandated Body are:

- a potential customer of the applying manufacturer;
 - the location relative to that manufacturer;
 - the capability to perform the duties described herein on the subject product
3. When no Mandated Body is available the SG will send the Application Form ACP003 – FORM01 to the Executive Board to assist in finding a Mandated Body.
 4. The SG will confirm the selection of the Mandated Body and will send further information as applicable.

ASD-CERT

SAMPLE

ACP003 - FORM01

Please complete this form and send to : ASD-CERT - Secretary General - Gulledele 94 - b.5 - 1200 Brussels - Belgium

Application for Product Certification

Manufacturer's reference:
[from Manufacturer's document referencing system e.g.] Xy/yz/2001-196

Manufacturer: Nuts & Bolts S.A.
Address: [Applicant's location and if different location where the products will be manufactured]
12345 Rue Sample
67890 Anywhere Village, Nowhere Country
Contact person's name: Mrs. Sandy Anybody
function: Head of Product Quality
phone: +32-2-775.8110 **fax:** +32-2-775.8111 **e-mail:** sandy.anybody@nutsbolts.com

We apply for certification of the following standard aerospace products:

EN Standards:
EN 2925, EN 2926, EN 3006, EN 3007,
EN 3293, EN 3326, EN 3614

Other Standards:

Target Date for Qualification: 28 February 2001

Quality System Certificates/Approvals held:

IAQG OASIS registration **ASD-EASE EASIS registration**
 No Yes: validity _____ No Yes: Company: EADS Hamburg.....
Date 10-Jun-99 Report No EADS-0001/99

Others (attach copy of certificates): ISO 9001:1994 by Any Accredited Assessor, Boeing, Airbus,

European Aerospace Companies (interested in) purchasing the above products:

EADS Toulouse, EADS Ottobrunn, EADS Hamburg, Rolls-Royce Bristol, ITP Zamudio, Alenia Milano,

*We understand that we will be liable for all expenses incurred in completing the work, regardless of the outcome.
Upon certification we will pay the registration fees.*

Name: Ms C. Chief **Function:** Quality Director

Signature: 

Date: 31-Aug-2001

To be filled in by ASD-CERT: Received by ASD-CERT Secretary General: _____
Quality System Approval with reference to EN 9100 is required: yes no

QUALITY SYSTEM ASSESSMENT - PROCEDURE**Purpose**

To provide the procedure to assess quality systems of manufacturers applying for product certification. Refer to documents 'A Policy on 9100 QMS Assessment and Certification, A/QC/25035, Requirements and Procedure for the European Aerospace Supplier Quality System Certification Scheme, A/QC/24281, and International Aerospace Standard prEN9104.

Procedure

1. The schedule for the assessment shall be established between the Mandated Body and the manufacturer directly, unless already under planned surveillance by an ASD-EASE member, or a recognised Sector Certification Scheme member, ref prEN9104.
2. The Mandated Body shall take care of the audit. He shall present a milestone schedule to all involved. The audit shall be performed by auditors meeting the criteria as defined by A/QC/24281 and making use of the Aerospace questionnaire, EN 9101 standard.

The audit report shall contain:

- * the summary of the questionnaire;
- * ACP004 - FORM01 presenting judgements and recommendations;
- * the concurrence of the manufacturer with the report.

The Mandated Body shall, as part of his judgement, include a review of the certification of the manufacturer by a recognised certification organization. This review comprises the audit report of the certification organization and clearance of non-conformities.

Furthermore the certification organization shall be accredited for the scope "aerospace" and its auditors shall be agreed by the aerospace industry in accordance with A/QC/24281.

The report of the audit, including ACP004 - FORM01, shall be sent to the SG.

4. The SG shall immediately send form ACP004 - FORM01 to ASD -CERT Executive Board for their approval decision and signature. Executive Board members shall return completed forms within 10 days.

On return of the forms, the SG shall prepare and sign an approval letter (see attached example). The approval of the quality system is valid for three years from the date of the report, after which it may be extended based on a new assessment by a Mandated Body, or evidence provided by the Mandated Body that the products conform to the standard constantly.

The SG shall update TR3040.

ASD-CERT

to be filled in by the Mandated Body

ACP004 - FORM01

QUALITY SYSTEM AUDIT - SUMMARY AND RECOMMENDATION	
Mandated Body (Auditor):	
Auditor's name:	
function:	
Manufacturer (Auditee):	
Address:	
Product range (according to TR 3040-1):	
<input type="checkbox"/> Bearings	<input type="checkbox"/> Electrical products
<input type="checkbox"/> Metallic materials	<input type="checkbox"/> Non-metallic materials
<input type="checkbox"/> Fasteners	<input type="checkbox"/> Hydraulic products
<input type="checkbox"/> Miscellaneous	
Summary of the Audit:	Audit report reference no.: _____
Auditor's Signature _____ Date: _____	
Summary to be continued on further pages: <input type="checkbox"/> No <input type="checkbox"/> Yes on _____ pages	
Recommendation of Mandated Body:	
Quality System of Manufacturer to be approved: <input type="checkbox"/> yes <input type="checkbox"/> no	
Name:	
Signature:	Date:
Decision of ASD-CERT Executive Board member:	
Quality System of Manufacturer Approved: <input type="checkbox"/> yes <input type="checkbox"/> no	
<input type="checkbox"/> yes on condition (see separate page)	
Name:	
Signature:	Date:

ASD-CERT

SAMPLE

ACP004 - FORM01

QUALITY SYSTEM AUDIT - SUMMARY AND RECOMMENDATION

Mandated Body (Auditor): Aerospace SA

9876 Lilienthal Weg

443322 Prime City

Country

Auditor's name: Mr. Aud Itor

function: Quality supplies

Manufacturer (Auditee): Nuts & Bolts S.A.

Address: *[locations subject to the audit, i.e., where the products will be manufactured]*

12345 Rue Sample

67890 Anywhere Village, Nowhere Country

Product range (according to TR 3040-1):

- Bearings
 Electrical products
 Fasteners
 Hydraulic products
 Metallic materials
 Non-metallic materials
 Miscellaneous

Summary of the Audit:

Audit report reference no.: AEROSPACE-2001-0234

All EN 9001 elements were covered during the audit performed 21 through 24 June 2001.

No major findings. 4 minor deviations – singular occurrence each and no interference between these dev.'s.

Corrective action was provided and is accepted for all 4 deviations.

Element “corrective action” was found impressive and beyond common state of the art.

Element “scrap of material” also not noted as deviation is subject for a recommendation to further develop this area to prevent from any break-down.

Auditor's Signature *A. Itor*

Date: 03-Jul-2001

Summary to be continued on further pages: No Yes on _____ pages

Recommendation of Mandated Body:

Quality System of Manufacturer to be approved: yes no

Name: Mr. E. Somebody *[focal point to ASD-CERT, as nominated by the mandated body or her/his deputy]*

Signature: *E. Somebody*

Date: 05-Jul-2001

Decision of ASD-CERT Executive Board member:

Quality System of Manufacturer Approved: yes no

yes on condition (see separate page)

Name:

Signature:

Date:

PRODUCT CERTIFICATION - PROCEDUREPurpose

To provide the procedure to certificate standard aerospace products.

Procedure

1. The SG shall inform the manufacturer and the relevant ASD standardization technical committee about the pending testing.
2. The Mandated Body shall participate in the testing. He shall
 - cooperate with the manufacturer regarding the preparation and execution of a qualification test programme (QTP) in accordance with the relevant standards and specifications;
 - monitor the testing and perform verifications, as appropriate.

The manufacturer shall provide the specified sample parts and the required manufacturing and inspection files of same, including those of the raw materials as appropriate.

After completion of the qualification testing a detailed report (QTR) shall be prepared by the manufacturer. The manufacturing route employed to manufacture the parts tested shall be established, agreed, signed and stamped in red, and retained by the manufacturer. See also ACP006.

The Mandated Body shall evaluate the qualification test report (QTR) mentioned above and prepare a Product Qualification Testing Report. (PQTR)

This report shall contain:

- a unique reference
 - date of qualification
 - reference to the sealed manufacturing route(s)
 - the detailed report of the test programme executed;
 - ACP005 - FORM01 presenting summary and recommendations;
 - the concurrence of the manufacturer with the report.
3. The summary of the test report, accompanied by ACP005 - FORM01, shall be sent to the SG.
 4. The SG shall send form ACP005 - FORM01 to ASD-CERT Executive Board for their approval decision and signature.
 5. If agreed by the EB members, the SG shall prepare and sign a certificate (see attachment to be added). This certificate is valid for three years after which it may be extended, based on a performance review by the original Mandated Body.

6. The SG shall publish the certificated standard aerospace product and its manufacturer in the A web site, and advise ASD-STAN to reissue TR 3040.
7. In due time before the end of the validity period, the SG shall have a Mandated Body perform an audit on the manufacturer to verify that the manufacturing process is still valid and then make a recommendation to ASD-CERT whether or not the certification can be continued.
8. The SG will prepare and sign a new certificate. This certificate is valid for three years after which it may be extended again, based on a performance review by the original Mandated Body.
9. The SG shall maintain records of tests report summaries, ACP 005 forms, certificates and pertinent correspondence.

ASD-CERT

to be filled in by the Mandated Body

ACP005 - FORM01

PRODUCT QUALIFICATION TESTING - SUMMARY AND RECOMMENDATION

Mandated Body (Auditor):

Manufacturer (Auditee):

Address:

Products subject to certification:

Product identification

(acc. to marking requirements in appl. std.):

Qualification document:

(document reference)

Sealed manufacturing route

(document reference)

Name :

Signature:

Date:

Recommendation of Mandated Body:

a. m. products of Manufacturer to be certificated: yes no

Name:

Signature:

Date:

Decision of ASD-CERT Executive Board member:

a. m. products of Manufacturer certificated: yes no

yes on condition (see separate page)

Name:

Signature:

Date:

ASD-CERT

SAMPLE

ACP005 - FORM01

PRODUCT QUALIFICATION TESTING - SUMMARY AND RECOMMENDATION

Mandated Body (Auditor): Aerospace SA

9876 Lilienthal Weg
443322 Prime City
Country

Manufacturer (Auditee): Nuts & Bolts S.A.

Address: [location subject to the audit, i.e., where the products will be manufactured]
12345 Rue Sample
67890 Anywhere Village, Nowhere Country

Products subject to certification:

Product identification <small>(acc. to marking requirements in appl. std.):</small>	Qualification document: <small>(document reference)</small>	Sealed manufacturing route <small>(document reference)</small>
EN2925-050030	ASAG-2925a-0023-2001	NB-Bolt-2925-050
EN2925-050042	ASAG-2925a-0023-2001	NB-Bolt-2925-050
EN2925-070068	ASAG-2997c-0025-2001	NB-Bolt-2925-070
EN2925-080026	ASAG-2997c-0025-2001	NB-Bolt-2925-080
EN2925-080034	ASAG-2997c-0025-2001	NB-Bolt-2925-080
EN2925-080054	ASAG-2997c-0025-2001	NB-Bolt-2925-080
continued on extra sheet	continued on extra sheet	continued on extra sheet

Name: A. Itor

Signature: *A. Itor*

Date: 12-Jul-2001

Recommendation of Mandated Body:

a. m. products of Manufacturer to be certificated: yes no

Name: E. Somebody

Signature: *E. Somebody*

Date: 15-Jul-2001

Decision of ASD-CERT Executive Board member:

a.m. products of Manufacturer certificated: yes no
 yes on condition (see separate page)

Name:

Signature:

Date:

MANUFACTURING RECORDS**Purpose**

To provide the procedure to be followed by a manufacturer and the Mandated Body to ensure that all manufacturing records are signed.

Procedure

- 1 The Mandated Body shall ensure that with regard to the production of the standard aerospace products at issue, that significant and/or risky operations and parameters are identified, that these operations and parameters are recorded and that manufacturing drawings and processes are recorded.
- 2 All records mentioned above shall be signed and stamped, (using the ASD-CERT stamp), by the Mandated Body, and signed by the manufacturer.
- 3 The manufacturer shall undertake not to change anything without the written authority of ASD-CERT. See also ACP 008.
4. The original set of manufacturing records shall be retained by the manufacturer, a copy may be retained by the MB.

PROCEDURE FOR CONTROLLING ASD CERT STAMPS

Purpose

To provide the procedure for assigning and controlling inspection stamps used to indicate that a particular manufacturing route was inspected and frozen at a manufacture by a nominated member of a Mandated Body.

To ensure that ASD-CERT maintains a record of stamps issued, indicating assignee, date of issue, and number of stamp; and that control is exercised with regard to loss, damage and reassignment of stamps.

Scope

This procedure applies to the ASD-CERT Secretary General and Mandated Body operations.

Responsibilities

The ASD-CERT SG is responsible for the assigning, control and maintaining records for all inspection stamps.

Procedure

1. All inspection stamps are assigned and controlled by the ASD-CERT SG in order to prevent unauthorised use.
2. A master list is maintained in the form of an Stamp Assignment Log. Each stamp is identified with a consecutive number which allows each to be assigned and traced to a particular MB.
3. All unused stamps shall be kept secure at the ASD-CERT SG's office.
4. For each Mandated Body one numbered stamp shall be issued and registered by the SG.
5. Mandated Bodies are responsible for the correct application of the stamp on manufacturing route documentation by authorised users, and the prevention of unauthorised use.
6. Mandate Bodies that relinquish their appointment shall immediately return their stamp(s) to the SG
7. In the event of a loss of a stamp the MB shall issue a report of the circumstances to the SG who will make appropriate changes to the Stamp Assignment log.

8. In the event that a stamp becomes damaged so as to affect its legibility it shall be returned to the SG for destruction. A replacement stamp shall be issued and records amended accordingly.

PROCEDURE FOR MANUFACTURING CHANGE REQUEST (MCR)

Purpose

To provide the procedure to be followed by a manufacturer to request a change to his manufacturing and/or inspection processes.

Procedure

- 1 The manufacturer wishing to incorporate a change to his sealed manufacturing route and/or inspection processes shall request ASD-CERT's approval by sending a Manufacturing Change Request, ACP008 - FORM01, to ASD-CERT.
- 2 The SG shall forward the MCR to the Mandated Body involved in the original certification asking for its recommendations. If agreed, the manufacturing route employed to manufacture the parts tested shall accordingly be changed, established, agreed and sealed.
- 3 This MCR may be reviewed by ASD-STAN which will give an advice to ASD-CERT.
- 4 The mandated Body shall provide recommendations, endorsing the MCR and return it to the SG who will seek confirmation from the Executive Board.
- 5 ASD-CERT SG will then inform the manufacturer about its decision.
- 6 The SG shall keep records of the MCR's and associated correspondence.

ASD-CERT to be filled in by the applying Manufacturer

ACP008 - FORM01

Please complete this form and send to : ASD-CERT - Secretary General - Gulledele 94 - b.5 - 1200 Brussels - Belgium

MANUFACTURING CHANGE REQUEST	Manufacturer's reference:
-------------------------------------	----------------------------------

Manufacturer:
Address:

Products subject to certification:

Product identification (acc. to marking requirements in appl. std.):	Product qualification certificate number:	Issue date of the PQ certificate

Proposed changes:

Reasons for changes:

Effective date of change:

For Manufacturer

Name :

Signature: _____ Date: _____

Recommendation of Mandated Body:

Changed manufacturing route is sealed; doc. ref:

a. m. changes to be certificated: yes no

Name:

Signature: _____ Date: _____

Decision of ASD-CERT Executive Board member:

a.m. products of Manufacturer certificated: yes no
 yes on condition (see separate page)



Name:

Signature: _____ Date: _____

ASD-CERT

SAMPLE fill in by Mandated Body

ACP008 - FORM01

Please complete this form and send to : <i>A-CERT - Secretary General - Guldelle 94 - b.5 - 1200 Brussels - Belgium</i>		
MANUFACTURING CHANGE REQUEST	Manufacturer's reference:	
Manufacturer: Nuts & Bolts S.A. Address: [location subject to the audit, i.e., where the products will be manufactured] 12345 Rue Sample 67890 Anywhere Village, Nowhere Country		
Products subject to certification:		
Product identification (acc. to marking requirements in appl. std.):	Product qualification certificate number:	Issue date of the PQ certificate
EN2925-050042	PQ 1020	15-May-1998
EN2925-070068	PQ 2324	26-Jul-2000
Proposed changes: Change of facilities for sequence 031 and 032.		
Reasons for changes: Replacement of previous equipment		
Effective date of change: immediately		
For Manufacturer		
Name : Ms C. Chief	Function: Quality Director	
Signature: 	Date: 25-Apr-2001	
Recommendation of Mandated Body:		
Changed manufacturing route is sealed; doc. ref: NB-Bolt-2925-050 <u>iss 2 &</u> NB-Bolt-2925-070 <u>iss 5</u>		
a. m. changes to be certified: <input checked="" type="checkbox"/> yes <input type="checkbox"/> no		
Name: E. Somebody		
Signature: 	Date: 12-Jul-2001	
Decision of ASD-CERT Executive Board member:		
a. m. products of Manufacturer certified: <input type="checkbox"/> yes <input type="checkbox"/> no <input type="checkbox"/> yes on condition (see separate page)		
Name:		
Signature:		
Date:		

**PROBLEMS WITH STANDARD AEROSPACE PRODUCTS
REPORT BY USERS**

Purpose

To provide the procedure to be followed by users to report on problems with standard aerospace products, and resulting actions in ASD-CERT.

Procedure

- 1 A user finding problems with standard aerospace products will normally report such problems to the manufacturer of the product. He may also report such problems to ASD-CERT. In any event, on receipt of such reports, or if the manufacturer recognises that he has released non-conforming parts for industry use, he shall immediately report such events to ASD-CERT.
- 2 The SG shall contact the MB who performed product qualification, and forward to him all pertinent information, requesting an immediate investigation.
- 3 The MB will investigate and report its findings and recommendations to the SG. Such recommendations could be to conduct a partial or full product requalification, or removal of qualification certification.
- 4 The SG shall forward the MB's reports and recommendations to the EB; to which the members will respond confirming the recommendations or other actions to be taken.
- 5 The SG shall launch actions with the manufacturer and MB consistent with the outcome of EB responses, and follow them through to conclusion.

APPEAL PROCEDURE

Purpose

To provide the procedure to be followed for appeals against decisions of ASD-CERT.

Procedure

- 1 Appeals shall be sent to ASD-CERT Secretary General who will send them to the Appeal Panel.
- 2 The Appeal Panel will investigate the appeal and will give a written judgement which will be sent to the SG. The SG shall provide copies to the ASD-CERT Executive Board and the appellant.
- 3 After due consideration ASD-CERT Executive Board will confirm its position in writing to the appellant via the SG.
- 4 The SG shall maintain records of appeals, Appeal Panel judgements and Executive Board decisions.

ASD-CERT SECRETARY GENERAL OFFICE

Purpose

To provide the terms of reference of ASD-CERT Secretary General, as realized via his office.

Terms of Reference

- 1 To perform all administrative and accounting tasks.
- 2 To produce and distribute ASD-CERT certificates.
- 3 To issue the list of certificated standard aerospace products and the approved manufacturers (TR 3040), and update the ASD-CERT web site as changes occur.
- 4 To manage the designation of Mandated Bodies and maintain a register
- 5 To establish fees and recover these from the manufacturers of certificated standard aerospace products, and maintain records.
- 6 To handle appeals.
- 7 To control and file electronically the ASD-CERT documents both for ASD-CERT and the manufacturers of standard aerospace products and the Mandated Bodies, as appropriate.

To maintain the Mandated Body members list authorised to sign ACP's forms, and use the ASD-CERT stamp
- 8 To keep and control records.

ABBREVIATIONS

ACP	ASD-CERT Procedure
ASD	AeroSpace and Defence Industries Association of Europe
ASD-EASE	ASD European Aerospace Supplier Evaluation association
ASD-STAN	ASD Aerospace Standardization association
EN	European Norm, a standard issued by CEN/CENELEC, the European Standardization Organization
SG	Secretary General
QTP	Qualification test Programme
QTR	Qualification Test Report
PQTR	Product Qualification Test Report
MB	Mandated Body